

**FIRE PROTECTION NOTES:**

1. PROVIDE A COMPLETE FULLY AUTOMATIC WET PIPE SYSTEM HYDRAULICALLY CALCULATED IN ACCORDANCE WITH THE STATE FIRE MARSHAL AND THE LATEST EDITION N.F.P.A. 13, 14, AND REQUIREMENTS OF ALL LOCAL AUTHORITIES HAVING JURISDICTION.
2. ALL FIRE PROTECTION EQUIPMENT, I.E. PIPING, VALVES, FITTINGS AND ACCESSORIES, ETC. SHALL BE RATED FOR A MAXIMUM WORKING PRESSURE OF 250 PSI.
3. PROVIDE PRESSURE REDUCING VALVES AT ALL SPRINKLER SYSTEM AND FIRE DEPARTMENT HOSE CONNECTIONS WHERE PRESSURES EXCEED 175 PSIG IN ACCORDANCE WITH CODE REQUIREMENTS. CONTRACTOR SHALL FIELD PRESSURE TEST SYSTEM AND DETERMINE WHERE PRESSURE REDUCING VALVES ARE REQUIRED.
4. USE PIPING AND FITTINGS FOR FIRE SUPPRESSION SYSTEMS WHICH ARE APPROVED FOR USE BY UNDERWRITERS' LABORATORIES AND FACTORY MUTUAL SYSTEM AND OF THE FOLLOWING TYPES; AND IN ACCORDANCE WITH NFPA, LOCAL CODES ALL AUTHORITIES HAVING JURISDICTION.
  - o) BLACK STEEL PIPING; MANUFACTURED TO SATISFY ASTM STANDARDS A53 OR A135.
5. ALL SPRINKLER PIPING SHALL BE INSTALLED SO THAT ALL PORTIONS OF THE SYSTEM CAN BE DRAINED BACK THROUGH THE DRAIN VALVE WHERE REQUIRED. PROVIDE DRAIN VALVES FOR ALL TRAPPED PORTIONS OF THE SYSTEM.
6. ALL FIRE EQUIPMENT THREADS SHALL CONFORM TO LOCAL FIRE DEPARTMENT STANDARDS.
7. ALL CONTROL VALVES - CHECK VALVES AND FLOW ALARM SWITCHES LOCATED ABOVE FINISHED CEILING SHALL BE ACCESSIBLE AND HAVE A NOTIFICATION MARKING TAG AS REQUIRED FOR INSPECTION VERIFICATION.
8. CONTRACTOR SHALL COORDINATE INSTALLATION OF ALL PLUMBING/SPRINKLER PIPING TO MAINTAIN PROPER CLEARANCES OVER AREA.

**PLUMBING NOTES:**

1. ALL WORK SHALL BE PERFORMED IN ACCORDANCE WITH 2006 INTERNATIONAL PLUMBING CODE.
2. ALL SOIL AND WASTE PIPING SHALL BE INSTALLED AT A MAXIMUM OF 1/8" (1%) PER FOOT GRADE UNLESS INDICATED OTHERWISE ON THE DRAWINGS.
3. PIPING AND/OR EQUIPMENT SHALL NOT BE SUPPORTED FROM STRUCTURAL MEMBERS WITHOUT PRIOR REVIEW AND APPROVAL FROM THE STRUCTURAL ENGINEER.
4. CONTRACTOR IS PROHIBITED FROM USING LEAD-BASED SOLDER.
5. PROVIDE ONE (1) TRAP PRIMER VALVE FOR EACH FLOOR DRAIN WITHOUT A CONSTANT SOURCE OF WATER SUPPLY TO MAINTAIN TRAP SEAL. PRIMER VALVE SHALL BE LOCATED IN AN ACCESSIBLE AREA AND CONNECTED TO THE NEAREST 3/4" COLD WATER LINE SERVING A FIXTURE.
6. BACK FLOW PREVENTER ASSEMBLY SHALL BE INSTALLED IN AN ACCESSIBLE LOCATION (APPROXIMATELY 4'-0" A.F.F.). PIPE RELIEF VALVE DISCHARGE PIPING TO NEAREST FLOOR DRAIN. DO NOT INSTALL ABOVE FINISHED CEILINGS.
7. DOUBLE CHECK VALVE ASSEMBLY SHALL BE INSTALLED IN AN ACCESSIBLE LOCATION (APPROXIMATELY 4'-0" A.F.F.). DO NOT INSTALL ABOVE FINISHED CEILINGS.
8. ALL PLUMBING FIXTURES AND EQUIPMENT SHALL CONFORM TO ALL APPLICABLE ENERGY CONSERVATION CODES.
9. ALL PIPING, VALVES, AND ACCESSORIES SERVING EQUIPMENT SHALL CONFORM TO ALL APPLICABLE ENERGY CONSERVATION CODES.
10. ANCILLARY SYSTEMS NOT ASSOCIATED WITH EQUIPMENT SHALL NOT BE INSTALLED SO AS TO INHIBIT SERVICING AND/OR REMOVAL OF SAID EQUIPMENT.
11. STERILIZE DOMESTIC WATER PIPING SYSTEM IN ACCORDANCE WITH STATE AND LOCAL CODES, AND BASE BUILDING SPECIFICATIONS.
12. CONTRACTOR SHALL BE RESPONSIBLE FOR PROVIDING AN ON-SITE FLOW TEST AT THE NEAREST FIRE HYDRANT. THE RESULTS OF THIS TEST SHALL BE SUBMITTED TO THE ENGINEER OF RECORD UPON COMPLETION OF THE TEST.

**GENERAL NOTES:**

1. ALL CONTRACT DOCUMENTS (SPECIFICATIONS AND DRAWINGS), I.E., ARCHITECTURAL, STRUCTURAL, MECHANICAL, PLUMBING, FIRE PROTECTION AND ELECTRICAL ARE COMPLEMENTARY AND MUST BE USED IN COMBINATION TO OBTAIN COMPLETE CONSTRUCTION INFORMATION.
2. ALL CONFLICTS, WHICH MAY PREVENT THE COMPLETION OF WORK AS INTENDED, SHALL BE BROUGHT TO THE ARCHITECT'S ATTENTION. THE CONTRACTOR SHALL NOT PROCEED WITH ANY RELATED WORK UNTIL ALL CONFLICTS ARE RESOLVED AND THE CLARIFYING INFORMATION IS ISSUED TO THE CONTRACTOR BY THE ARCHITECT.
3. IT IS THE INTENTION OF THESE DRAWINGS TO CALL FOR FINISHED WORK, I.E., FULLY ADJUSTED, TESTED, AND READY FOR OPERATION. WHEREVER THE WORD "PROVIDE" IS USED, IT SHALL MEAN, "FURNISH AND INSTALL COMPLETE AND READY FOR USE."
4. THE PLUMBING DRAWINGS ARE DIAGRAMMATIC AND DO NOT NECESSARILY SHOW EVERY COMPONENT AND/OR ACCESSORY REQUIRED FOR A COMPLETE INSTALLATION. THE CONTRACTOR SHALL INCLUDE SUCH ITEMS AS ARE REQUIRED TO ENSURE THAT THE ENTIRE SYSTEM IS FUNCTIONING IN COMPLIANCE WITH APPLICABLE CODES, ACCEPTED INDUSTRY STANDARDS, AND MANUFACTURER'S INSTALLATION REQUIREMENTS/RECOMMENDATIONS UPON COMPLETION OF THE WORK.
5. ALL CUTTING, DRILLING AND PATCHING OF WALLS, FLOORS, AND/OR STRUCTURAL MEMBERS FOR THE INSTALLATION OF THE PLUMBING AND FIRE PROTECTION SYSTEMS SHALL BE PROVIDED. STRUCTURAL COMPONENTS SHALL NOT BE CUT, DRILLED OR MODIFIED IN A WAY WITHOUT THE STRUCTURAL ENGINEER'S REVIEW AND PRIOR WRITTEN APPROVAL.
6. PROVIDE NFPA APPROVED FIRE STOPPING WHERE PIPES PENETRATE FIRE RATED FLOORS AND WALLS.

ELECTRIC TANKLESS WATER HEATER SCHEDULE						
MARK	SERVICE	STORAGE IN GALLONS	RECOVERY AT 100' RISE	ELECTRICAL	ELEMENT WATTAGE	MAKE AND MODEL
IWH-1	INSTANTANEOUS WATER HEATER	---	---	208/1ø/60Hz	4.1kw	EEMAX TANKLESS MODEL SPEX4208TML WITH BOTTOM CONNECTION.

PLUMBING FIXTURE AND CONNECTION SCHEDULE								
SYMBOL	DESCRIPTION	SIZE OF CONNECTION					REMARKS	WATER CONSERVATION
		TRAP	SS	SV	CW	H.W.		
EDF-1	ELECTRIC DRINKING FOUNTAIN	1-1/4"	2"	2"	1/2"		HALSEY TAYLOR HTHBHV8BBL ADA BARRIER-FREE TWO LEVEL WALL MOUNT FOUNTAIN WITH BOTTLE FILLER HVRH7HB, MCGUIRE NO. 8088 CHROME-PLATED ADJUSTABLE P-TRAP WITH CLEANOUT PLUG, 1-1/4" TRAP NIPPLE AND CHROME-PLATED STOP VALVE IN COLD WATER LINE. LOCATED INSIDE CABINET. REFER TO ARCHITECT FOR MOUNTING HEIGHTS.	

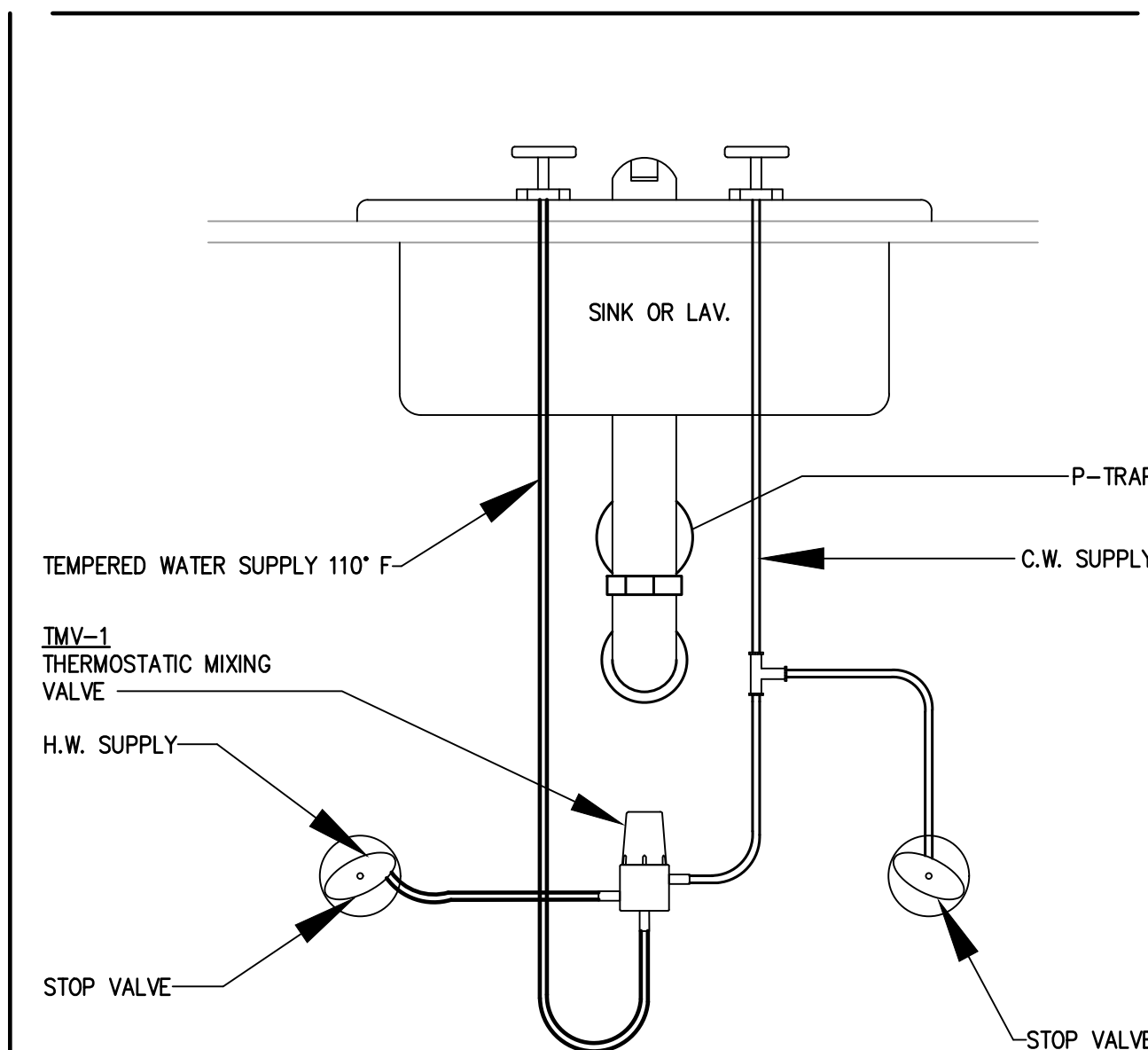

**02 THERMOSTATIC MIXING VALVE TMV-1**  
SCALE: NONE

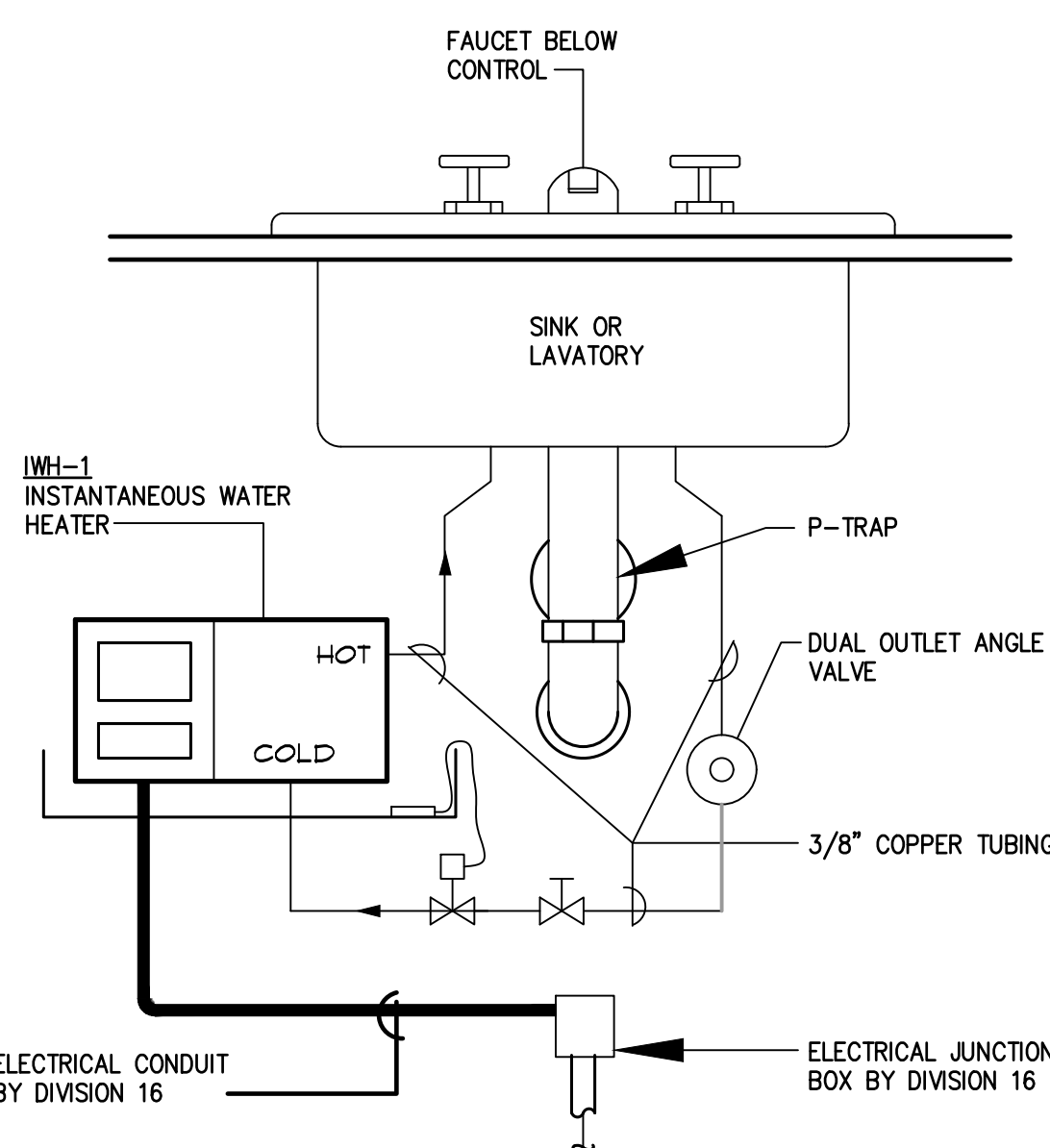

**03 INSTANTANEOUS WATER HEATER DET.**  
SCALE: NONE

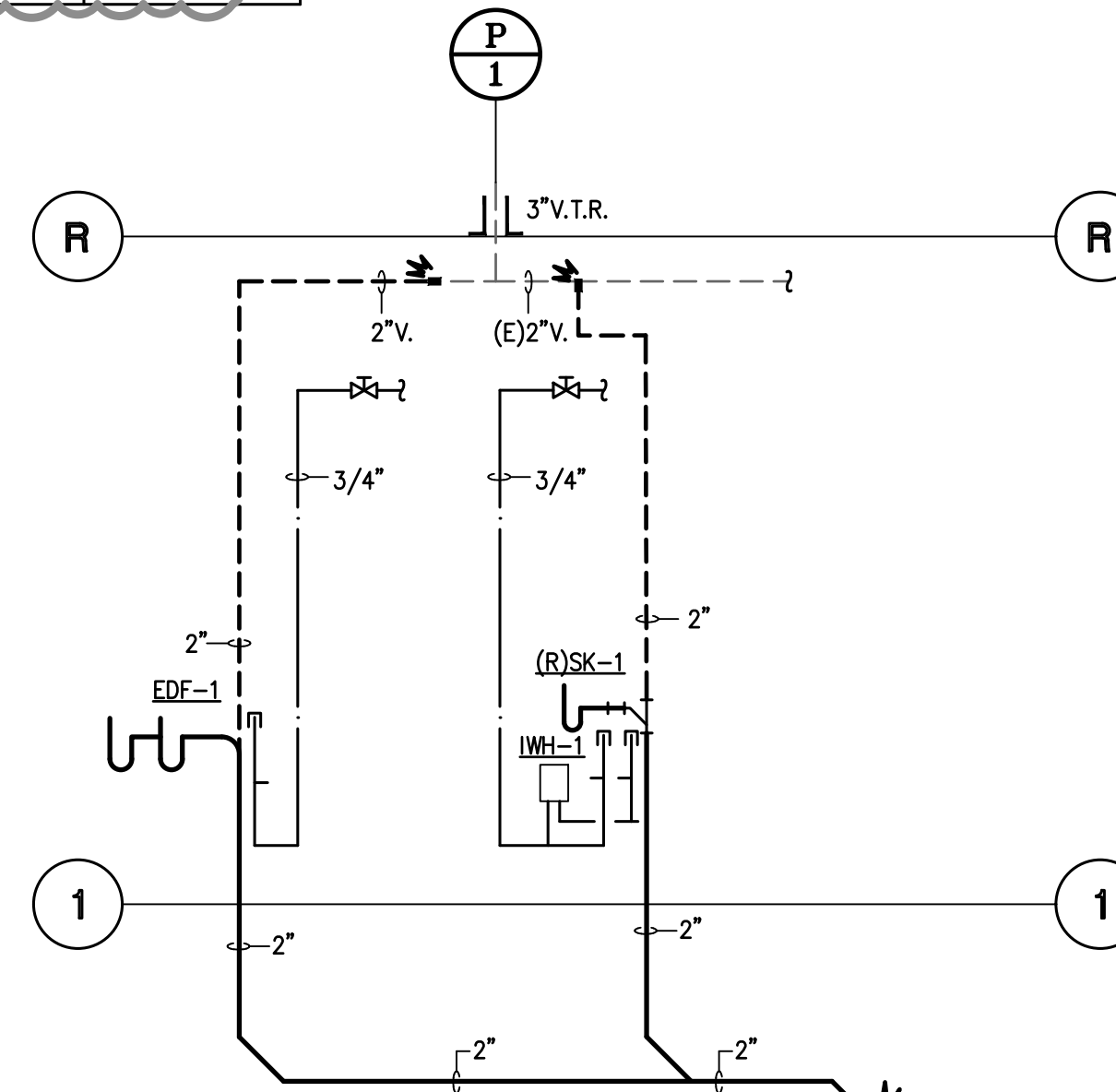

**01 PLUMBING RISER DIAGRAM**  
SCALE: NONE

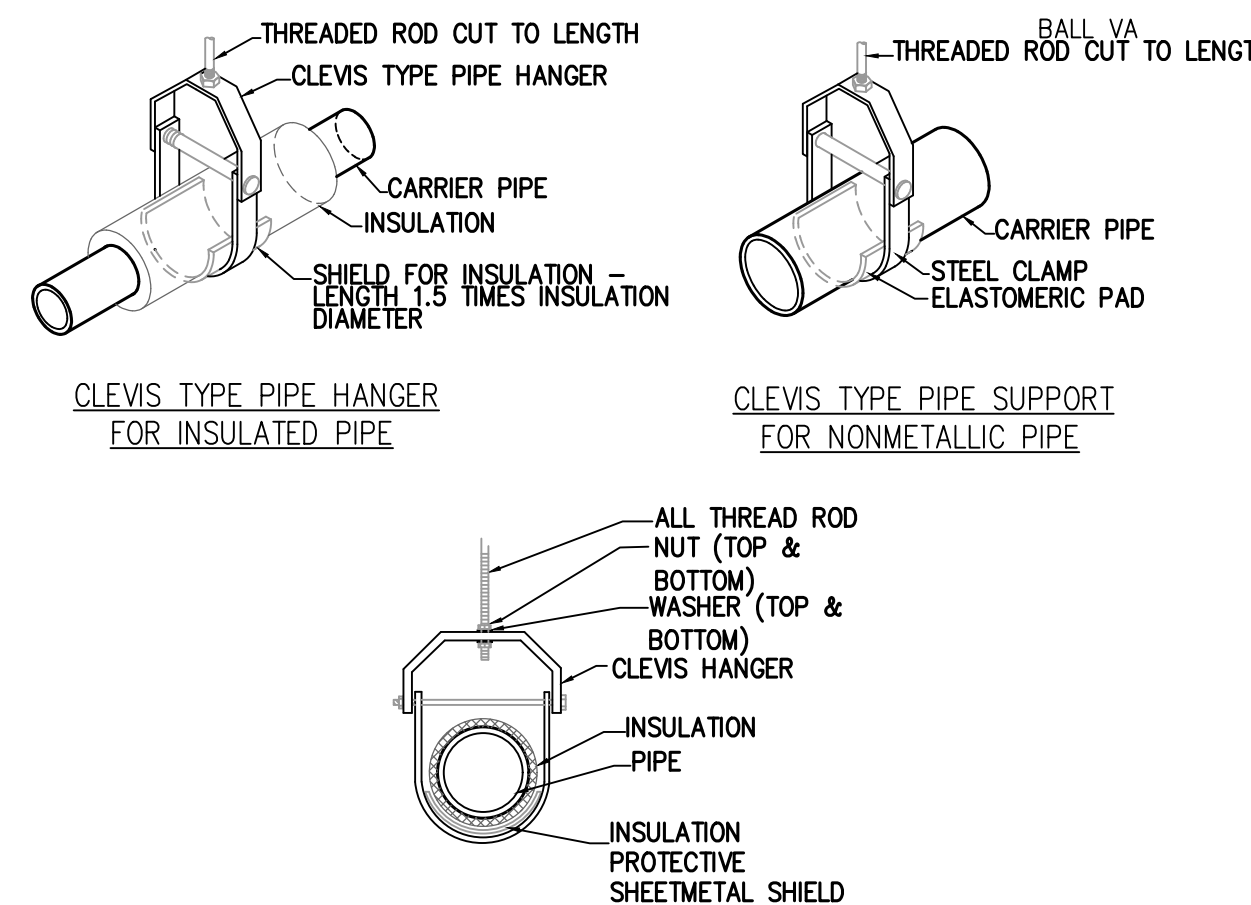

- NOTES:**
1. REFER TO MANUFACTURERS SPECIFICATIONS FOR ADDITIONAL INFORMATION.
  2. 16 GA. GALVANIZED SHEET STEEL SADDLE AT LEAST 12" LONG. (INSULATED LINES ONLY)
  3. INSULATION WHERE SPECIFIED.

**04 CLEVIS PIPE HANGER SUPPORT DETAIL**  
SCALE: NONE

**PLUMBING LEGEND**

SYMBOL	DESCRIPTION
---	SANITARY SEWER PIPING
---	VENT PIPING
---	DOMESTIC COLD WATER
---	DOMESTIC HOT WATER
---	DOMESTIC HOT WATER RETURN
---	EXISTING SANITARY SEWER PIPING
---	EXISTING VENT PIPING
---	EXISTING DOMESTIC COLD WATER
---	EXISTING HOT WATER
---	EXISTING HOT WATER RETURN
---	NEW CONNECTION TO EXISTING
---	ABOVE FINISHED FLOOR
---	BELOW FLOOR
---	GATE VALVE
---	CHECK VALVE
---	PRESSURE RELIEF VALVE
---	UNION
---	PRESSURE GAUGE
---	THERMOMETER
---	CONDENSATE DRAIN LINE
---	EXISTING
---	ITEMS TO BE REMOVED
---	ELBOW UP
---	ELBOW RISE OR DN. THROUGH SLAB
---	FLOOR CLEANOUT
---	CLEANOUT
---	FLOOR DRAIN

DISREGARD LEGEND ITEMS NOT INDICATED ON DRAWINGS

**PIPING MATERIAL SCHEDULE**

PIPING FUNCTION	PIPING MATERIAL
SANITARY WASTE BELOW GRADE	SCHEDULE 40 PVC
SANITARY WASTE ABOVE GROUND	NO-HUB CAST IRON OR SCHEDULE 40 PVC
SANITARY VENT	NO-HUB CAST IRON OR SCHEDULE 40 PVC
DOMESTIC HOT & COLD WATER	COPPER, TYPE "L" HARD DRAWN
FIRE SPRINKLER ABOVE GROUND	BLACK STEEL SCHEDULE 40

**NOTE:**  
NO HUB COUPLING SHALL HAVE A SHIELD CONSTRUCTED OF 304 CORRUGATED STAINLESS STEEL WITH A MINIMUM THICKNESS OF .016. COUPLING SIZE 1-1/2" & 4" SHALL HAVE FOUR (4) BANDS: APPROVED MANUFACTURERS HUSKY SD 4000 AND MISSION. NO TWO BANDS ARE ACCEPT

**LEGEND OF PLUMBING SYMBOLS**  
DISREGARD LEGEND ITEMS NOT INDICATED ON DRAWINGS

SYMBOLS	DESCRIPTION	SIZE OF CONNECTION					
		SANITARY	TRAP	VENT	C.W.	H.W.	L.W.
W C	WATER CLOSET (FLUSH VALVE)	4"	-	2"	1"	-	-
U	URINAL	2"	-	2"	3/4"	-	-
L	LAVATORY	2"	1-1/4"	1-1/4"	1/2"	1/2"	-
BT	BATH TUB	2"	1-1/2"	1-1/2"	1/2"	1/2"	-
MS	MOP SINK	-	2"	2"	1/2"	1/2"	-
SK-X*	SINK (BY ARCHITECT)	-	1-1/2"	2"	1/2"	1/2"	-
SH	SHOWER	-	2"	2"	1/2"	1/2"	-
EDF	ELECTRIC DRINKING FOUNTAIN	-	1-1/4"	1-1/4"	1/2"	-	-
DF	DRINKING FOUNTAIN	-	1-1/4"	1-1/4"	1/2"	-	1/2"



ARCHITECTURE PLANNING INTERIOR DESIGN  
15810 PARK TEN PLACE, SUITE 300  
HOUSTON, TEXAS 77084  
713-465-4650  
www.sligroup.com

NECHES LUMBERTON OFFICE ADDITION  
299 Country Lane at U.S. 69  
Lumberton, Texas 77657

ISSUED FOR	DATE
ISSUED FOR CLIENT APPROVAL	
ISSUED FOR BIDDING	04/30/2026
ISSUED FOR PERMIT	04/30/2026
ISSUED FOR CONSTRUCTION	

MARK	DESCRIPTION	DATE
	REVIEW SET	03-27-2026
	90% REVIEW SET	04-13-2026
	BID AND PERMIT	04-30-2026
	ADDENDUM C	06-17-2026

The information, ideas, designs, details, layouts, techniques, features, arrangements, plans, sequences, dimensions, allowances, tolerances, conceptions, specifications, intentions, technology or embodiments, as illustrated, arranged, displayed, noted, recorded, indicated, represented, disclosed, evidenced, detailed or otherwise reduced to tangible form hereon, either expressly, inherently or by implication, are the confidential and proprietary information of SLI Design, Inc. and shall not be used for any purpose other than the specific project or undertaking identified on the drawing title block or legend for which they are and have been prepared by SLI Design, Inc. Any other reproduction, disclosure or use of any portion of the confidential and proprietary information of SLI Design, Inc. shall be a breach of the obligation of confidence created by the acceptance of this drawing from SLI Design, Inc. for a specific project or Contract. Any copying, duplicating, reproducing, utilization, alteration, modification, revision or change to this drawing, is expressly prohibited unless done with the prior written consent or approval of SLI Design, Inc. and shall not be undertaken without receipt of such prior written approval. This drawing is loaned by SLI Design, Inc. for the limited purpose of complying with a specific Contract. The drawing remains the property of SLI Design, Inc. and shall be returned upon request or completion of the contract, unless specifically authorized by Contract, under which it was loaned.

DESIGN TEAM  
PM: JG  
MECHANICAL: CC  
ELECTRICAL: JG  
PLUMBING: JG  
CHECKED-BY: JG

DRAWING TITLE  
**PLUMBING INFORMATION**

SHEET NO.  
**P-1.00**

**E.I.B.E.** Mechanical Electrical Plumbing  
CONSULTING ENGINEERS  
12603 Southwest Frwy, Ste 170, Stafford, TX 77477  
Tel: (713) 840-0177 / Firm Reg. No: 5638

